

USER MANUAL

Modular Convenience Counter



WARNING

Read the instructions before using the machine.

KEEP THIS USER MANUAL FOR FUTURE USE

© 2021 Fri-Jado B.V., Oud Gastel, The Netherlands.

We advise you to contact your supplier for the guarantee period and conditions. Further we refer to our General Terms and Conditions for Sales and Delivery that are available upon request.

The manufacturer does not accept any liability for damage or injury caused by failing to adhere to these regulations or by not observing the usual caution or care in actions, operation, maintenance or repair activities, even if not explicitly described in this manual.

As a result of constant commitment to improvement, it may happen that your unit deviates in detail from what is described in this manual. For this reason, the given instructions are only a guideline for the installation, use, maintenance and repair of the unit referred to in this manual.

This manual has been composed with the utmost care. The manufacturer shall, however, not be held responsible for any mistakes in this manual nor for any consequences thereof.

The user is allowed to copy this manual for own use. Further all rights are reserved and nothing in this manual may be reproduced and/or made public in any way.

Modifications:

In case of unauthorized modifications in or on the unit, every liability on the part of the manufacturer becomes null and void.

CONTENTS

1.	INTRODUCTION	5
1.1	General.....	5
1.2	Identification of the unit.....	5
1.3	Pictograms and symbols.....	5
1.4	Safety instructions	6
1.4.1	General.....	6
1.4.2	Cold units with R290 (propane) refrigerant	7
1.4.3	Moving (when applicable)	8
1.4.4	Outdoor use restrictions.....	8
1.5	Hygiene	8
1.6	Service and technical support	8
1.7	Storage.....	9
1.8	Disposal.....	9
2.	DESCRIPTION OF THE UNIT	10
2.1	Technical description	10
2.2	Intended use.....	10
2.3	Accessories	11
3.	INSTALLATION AND FIRST USE	12
3.1	Unpacking the unit	12
3.1.1	Unpacking the front doors (optional)	13
3.2	Installation and positioning.....	14
3.2.1	Level the unit	14
3.2.2	Mounting the plinths.....	15
3.2.3	Mounting front doors (optional)	16
3.2.4	Applying price rail	17
3.3	Drop-in units	17
3.4	Repositioning the glass shelves.....	18
3.4.1	Cold FS/SS models & Hot FS models.....	18
3.4.2	Hot SS models.....	19
3.5	Plateau Options	19
3.6	Hot FS models (Humidification)	20
3.6.1	Water connection automatic	20
3.6.2	Manually fill.....	21
3.7	First use.....	22
4.	OPERATION AND USE	23
4.1	Cold Units	23
4.2	Hot Unit.....	25
5.	CLEANING AND MAINTENANCE	27
5.1	Maintenance schedule	27
5.2	Daily Cleaning.....	27

5.3	Weekly Cleaning.....	27
5.4	Cleaning Glass Panes	28
5.5	Cleaning air guides and fans Hot FS models	34
5.6	Cleaning the condenser (Cold units).....	36
6.	MALFUNCTIONS AND SERVICE.....	37
6.1	Cold units.....	37
6.2	Replace the mains cord	37
7.	TECHNICAL SPECIFICATIONS	38
7.1	Cold units.....	38
7.2	Hot units	40

1. INTRODUCTION

1.1 General

This manual is intended for the user of the MCC (Modular Convenience Counter). The features and controls are being described, along with directions for the safest and most efficient use, in order to guarantee a long life of the unit.

This appliance is intended to be used for commercial applications, for example in kitchens of restaurants, canteens, hospitals and in commercial enterprises such as bakeries, butcheries, etc., but not for continuous mass production of food.

All pictograms, symbols and drawings in this manual apply to all available MCC models.

1.2 Identification of the unit

The identification plate can be found on the outside of the machine, and contains the following data:

- Name of the supplier or the manufacturer
- Model
- Serial number
- Year of construction
- Voltage
- Frequency
- Power consumption

1.3 Pictograms and symbols

In this manual, the following pictograms and symbols are used:



WARNING

Possible physical injury or serious damage to the unit, if the instructions are not carefully followed.



WARNING

Risk of Fire.



WARNING

Hazardous electrical voltage.



WARNING

Danger of getting injured by hot surfaces.



SAFETY

Wear safety gloves for installation and dismantling.



SAFETY

Wear eye protection when working on the refrigeration system.



Suggestions and recommendations to simplify indicated actions.



Recycling symbol.

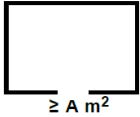

Minimum room floor area.

1.4 Safety instructions



WARNING

Cold units: Risk of Fire or explosion. Flammable refrigerant used.



WARNING

The outside and shelves of the unit can be very hot.



WARNING

The maximum load on top of the unit may never exceed 10 kg (22 lbs.).

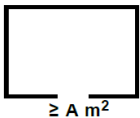

MINIMUM ROOM FLOOR AREA

Refer to the data label on the unit for the required floor area.



WARNING

See installation instructions for grounding requirements.



WARNING

Always use the brakes on both front wheels:

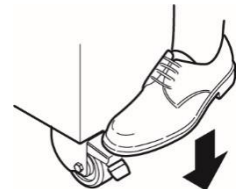

1.4.1 General

The user of the unit will be fully responsible for abiding the locally prevailing safety- rules and regulations.

The unit may be operated by qualified and authorized persons only. Anyone working on or with this unit must be familiar with the contents of this manual and carefully follow all guidelines and instructions. Never change the order of the steps to be performed. The management must instruct the personnel on the basis of this manual and follow all instructions and regulations.

The pictograms, labels, instructions and warning signs attached to the unit, are part of the safety measures. They may never be covered or removed, and have to be clearly visible during the entire lifetime of the unit.

Immediately repair or replace damaged or illegible pictograms, warnings and instructions.

- To avoid short-circuiting, never clean the unit using a water hose. For cleaning instructions, see section 5.
- The shelves, glass and back of the hot unit can get hot.
- The unit must be cleaned regularly to ensure proper functioning.
- Do not store explosive substances such as aerosol cans with flammable propellant in this appliance.
- This appliance can be used by children aged from 8 years and above and persons with reduced physical, sensory or mental capabilities or lack of experience and knowledge if they have been given supervision or instruction concerning use of the appliance in a safe way and understand the hazards involved.
- Children shall not play with the appliance.
- Cleaning and user maintenance shall not be performed by children without supervision.

1.4.2 Cold units with R290 (propane) refrigerant



Propane refrigerant is environmentally friendly but also highly flammable. It is non-toxic with zero Ozone Depletion Potential (ODP) and very low Global Warming Potential (GWP).

Read this manual carefully and follow all precautions described herein.



R290

WARNING

The propane refrigerant is highly flammable. All safety precautions must be followed.

Keep all ventilation openings in the housing of the appliance or in the installation unobstructed.

Do not use mechanical devices or other means to accelerate the defrosting process, other than those recommended by the manufacturer.

Do not damage the refrigerating circuit.

Do not use electrical appliances inside the food/ice storage compartments unless they are of the type recommended by the manufacturer.

Propane refrigerant does not contain odorants.



SAFETY

Wear eye protection when working on the refrigeration system.

- Install the unit in a well ventilated area with sufficient floor space: refer to the data plate for minimum space requirement.
- Do not install the unit in basements, in area's with open flames or high surface temperatures.
- Do not tamper with the system.
- The system must be installed and maintained by qualified persons only.
- The ventilation openings of the cladding of the unit (including accessories) must not be blocked or covered. Ensure that the air circulation remain unobstructed.
- Electrical devices used within this unit must be certified by the applicable ATEX directive.

Residual risks:

- Sparks from electrical devices or hot surfaces may unintentionally ignite possible leaked refrigerant gas.

1.4.3 Moving (when applicable)

When moving the unit:

- Before moving the unit, first switch off the mains voltage by pulling the plug from the wall socket.
- Remove pans containing a liquid product from the unit.
- Always keep the unit in upright position.
- Make sure that the wheels can move freely, so they never touch the power lead.

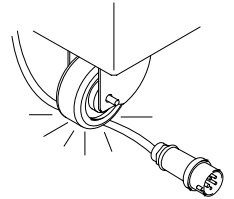
1.4.4 Outdoor use restrictions

WARNING

To avoid short-circuiting, the units may not be used outdoors or in a rainy or very moist environment.

1.5 Hygiene

WARNING

Immediately remove products in damaged packaging from the equipment and destroy the products. Clean all components that have come in contact with products from damaged packaging.

The quality of a fresh product always depends on hygiene. It is essential that products are packaged immediately after preparation. Prevent fresh raw vegetables or already prepared, cooled products from coming into contact with raw meat products to avoid transmitting salmonella. First thoroughly clean hands and/or tools that have touched raw meat.

For hot products, the core temperature of the products at packaging should at least be 85 °C (185 °F).

Refer to the cleaning instructions of section 5.

1.6 Service and technical support

The electrical schematics of your unit is included. In case of malfunctions you can contact your dealer/service agent. Make sure you have the following data available:

- Model.
- Serial number.

This data can be found on the identification plate.

1.7 Storage

If the unit will not be used temporarily, and will be stored, follow these instructions:

- Clean the unit thoroughly.
- Wrap the unit from getting dusty.
- Store the unit in a dry, non-condensing environment.
- Do not expose units with R290 refrigerant during storage and transport to temperatures higher than 70 °C (158 °F).
- Ensure good ventilation.
- Hot FS models: empty water tray.

1.8 Disposal



Dispose of the machine, any components or lubricants removed from it safely in accordance with all local and national safety and environment requirements.



WARNING

Cold units: Propane refrigerant is highly flammable. All safety precautions must be followed.

2. DESCRIPTION OF THE UNIT

2.1 Technical description

The panels are made of galvanized steel plating, stainless steel or aluminum. Some of the visible internal and external parts have been provided with a powder coating. The glass used is tempered. The unit can be moved by means of a pallet truck. The controls for operating the appliance have been mounted on the operator side of the unit. The product contact parts are made of stainless steel AISI 304 or AISI 430 and tempered glass.

MCC Cold units:

Cooling is achieved by means of a thermostatic temperature-controlled cold airflow. The cold air is passed via the back and shelves over the products. Self-serve models have an additional set of fans mounted in the top to create a stable air curtain on the open side of the cabinet to minimize the infiltration of warm ambient air. The air on the front side passes through the suction grid in the bottom of the unit.

The temperature of the airflow is controlled electronically. The electronically-controlled thermostat is factory programmed for the correct temperature. The set temperature can be changed from -6 °C to +0 °C (21.2 °F to 32 °F).

The units can be connected to a fixed drainage system or an optional evaporation tray to evacuate condensation water. One LED-module per level provides for lighting of the products. Lighting will automatically go on when switching on the cooling. Self-serve models can be fitted with an option night curtain.

MCC Hot units:

Heating in hot self-serve units is achieved by means of heated shelves in combination with an hot-air curtain per shelf. The air curtain isolates the hot air inside the unit from the ambient air.

Hot full serve units have a single heat source in the base of the cabinet and use fans to distribute the heat throughout the cabinet.

An electronic thermostat controls the temperature. The electronic thermostat has been set at the correct value at the factory. This value can be changed for self-serve models between 40 °C and 70 °C (104 °F and 158 °F) and for full serve models between 40 °C and 85 °C (104 °F and 185 °F). One LED-module per level provides for lighting of the products. The LED-lighting and the heating are switched on and off separately.

Full serve models can be fitted with an optional humidification system in the form of a passive water tray.

2.2 Intended use

Self-serve models (SS models) have been designed solely to keep packaged products cold or warm and to display them. Full serve models (FS models) can be used for unpacked foodstuff as well. Any other use will not be regarded as intended use.

The manufacturer accepts no liability whatsoever for loss or injury caused by failing to strictly adhere to the safety guidelines and instructions in this manual or due to carelessness during installation, use, maintenance and repair of the unit referred to in this manual and any of its accessories.

Use the unit in perfect technical condition only.

2.3 Accessories

Your unit contains the following standard accessories:

- User manual.
- Plinth set.
- Front doors (when applicable).

For optional accessories see www.frijado.com.

3. INSTALLATION AND FIRST USE



All packing materials used for this unit are suited for recycling.

Before and during unpacking, check the state of the unit. In case of damage, store the packing material, and contact the transporter within fifteen working days after receiving the goods.

3.1 Unpacking the unit

The MCC is placed inside a crate during transport.

1. Remove the top crate pane and foam.
2. Remove the front and rear boards.
3. Remove both side boards.
4. Lift the unit from the support beams using a pallet truck or forklift.
5. Remove the supporting beams.
6. Observe the safety and warning signs.

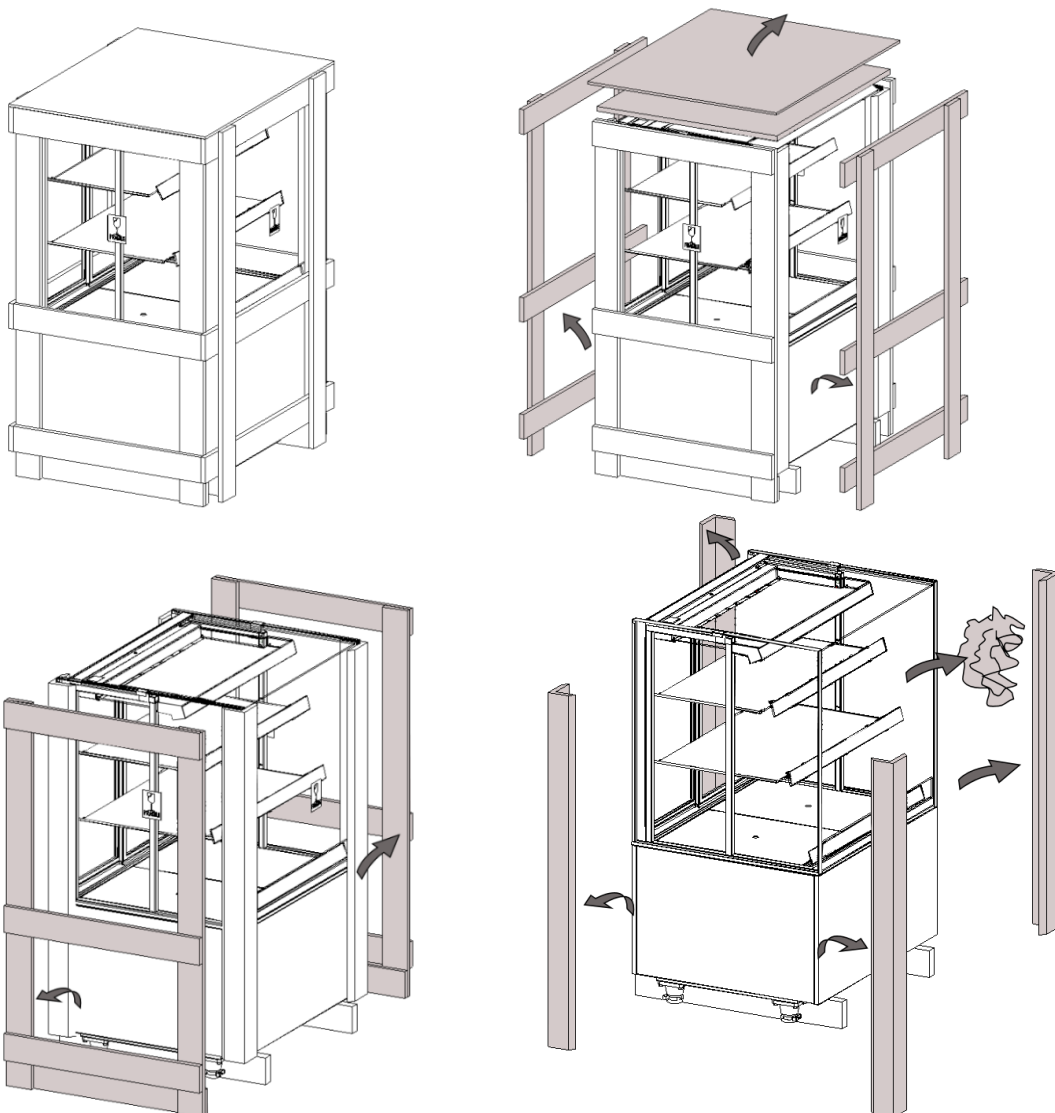

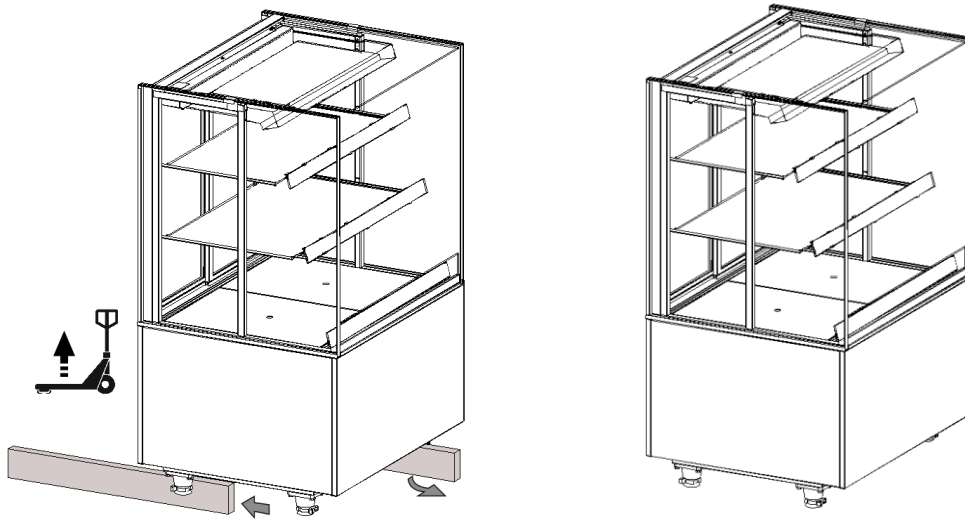

3.1.1 Unpacking the front doors (optional)

The 2 front doors and 4 plastic washers are placed in a crate during transport.

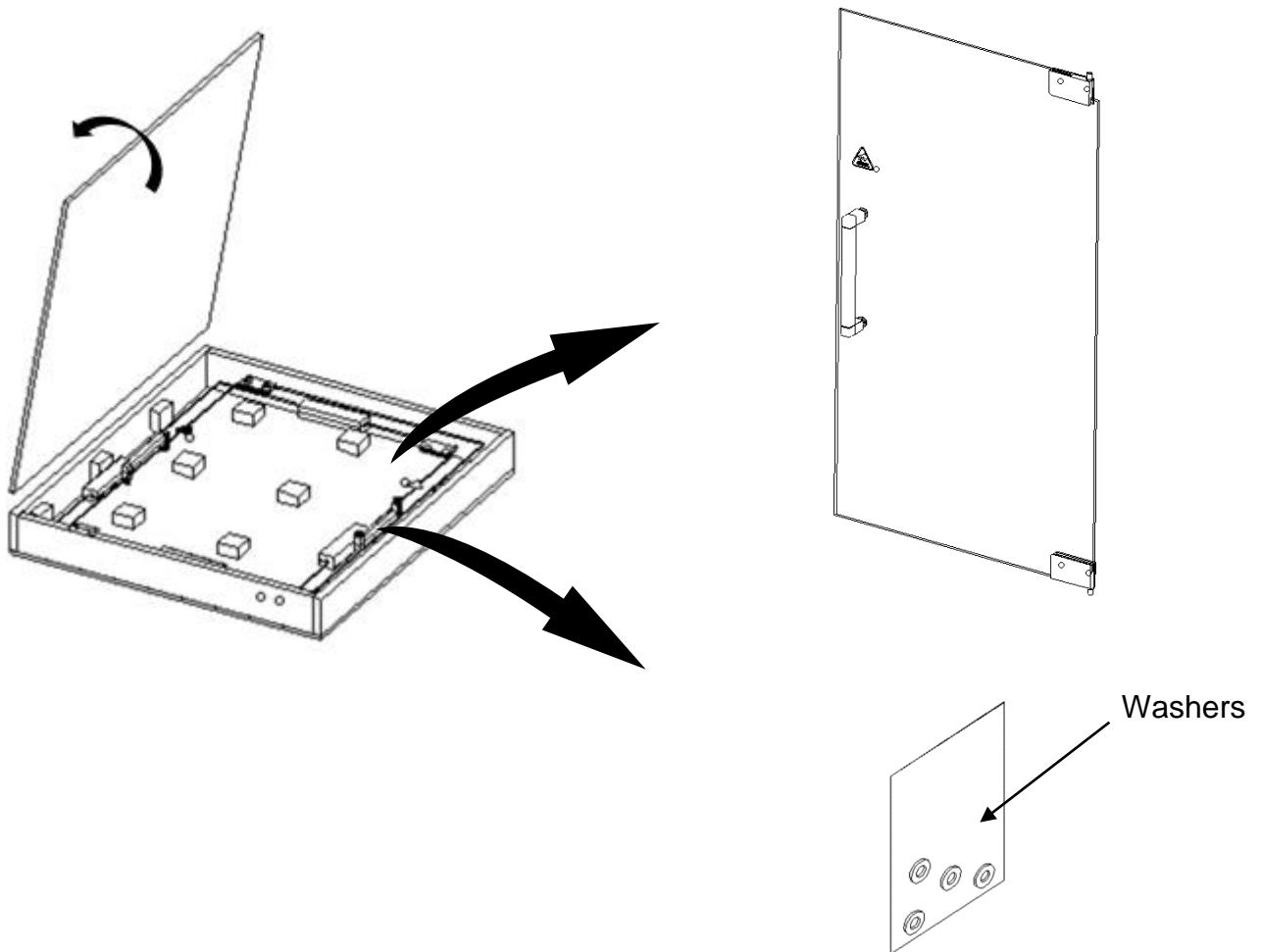

3.2 Installation and positioning



WARNING

Cold units: The propane refrigerant is highly flammable. All safety precautions must be followed.



WARNING

Electric chock hazard. Grounding instructions: only connect the appliance to an alternating current provided by a grounded wall socket, with a mains voltage in accordance with the information indicated on the data plate of the appliance.

It is the consumer's responsibility to make sure the electrical installation conforms with current national and local codes and wiring regulations.

Do not use a multi plug or extension cord. Such can result in fire, electrical shock, or other personal injury.

Failure to follow these instructions can result in death or serious injury.



WARNING

Position the unit on a flat and horizontal surface. A temporally inclined plane of maximum 5° is allowed.

- Place the unit level on a sufficiently sturdy floor. Keep the weight of the unit in mind. Use a levelling instrument to level the unit by adjusting the unit's legs.
- Be sure that the personnel have sufficient room to work with the unit.
- Keep a distance of at least 150 mm (6 inch) between the back wall and the unit.
- While positioning, keep the unit out of children's reach.
- Do not position a unit near a doorway, a ventilation device or a refrigerator in order to avoid any negative effects on the unit's operation by a cold airflow. The unit is designed for a maximum draft of 0.2 m/s (0.65 ft./sec).
- Do not place into direct sunlight.
- Be sure that the ambient temperature for cold models remains between 10 °C - 25 °C (50 °F - 77 °F) and that the relative air humidity remains below 60%. Cold units have been designed to operate at climate class 3 (according to ISO 23953). Hot units should not be used below 20 °C (68 °F) ambient temperatures.
- The unit has a mains plug, and must be connected to a wall socket with the proper mains voltage. The wall socket must be mounted by a certified electrician.
- Keep the plinth free from any obstacles to ensure ventilation.
- Hot FS models: Strongly advice to connect unit to a fixed drainage.

3.2.1 Level the unit

Place the unit on a sturdy, flat surface and level the unit by adjusting the unit's legs (max. +15mm).

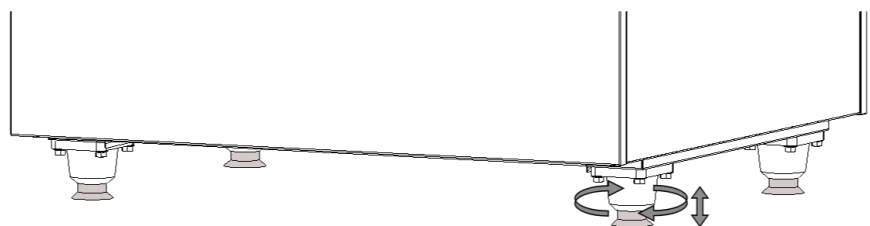

3.2.2 Mounting the plinths

Place the rear plinth by attaching it to both rear adjustable legs using its two clamps.

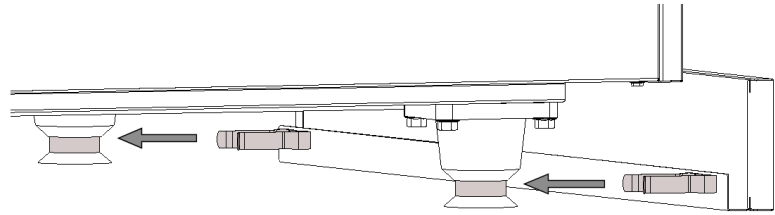

Insert the pegs of both side plinths into the slots of the rear plinth.

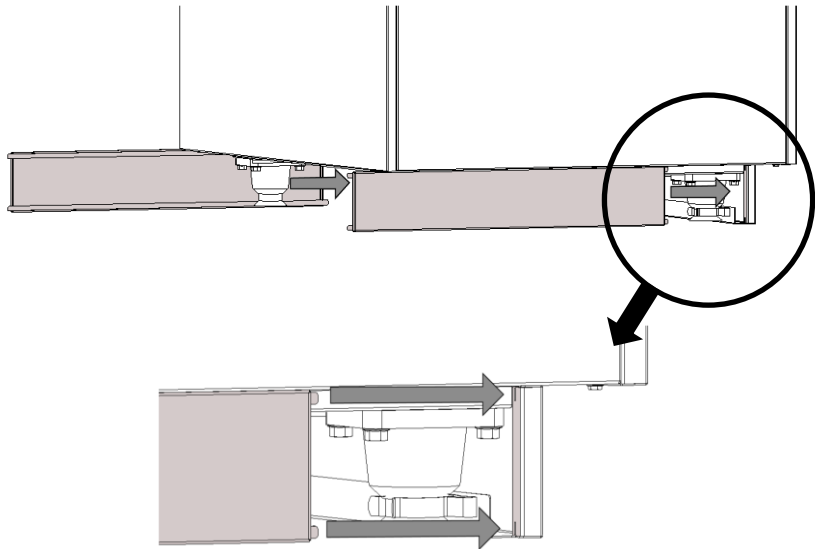

Secure the side plinths by inserting the pegs into the slots of the front plinth, while clamping the front plinth to the front adjustable legs.

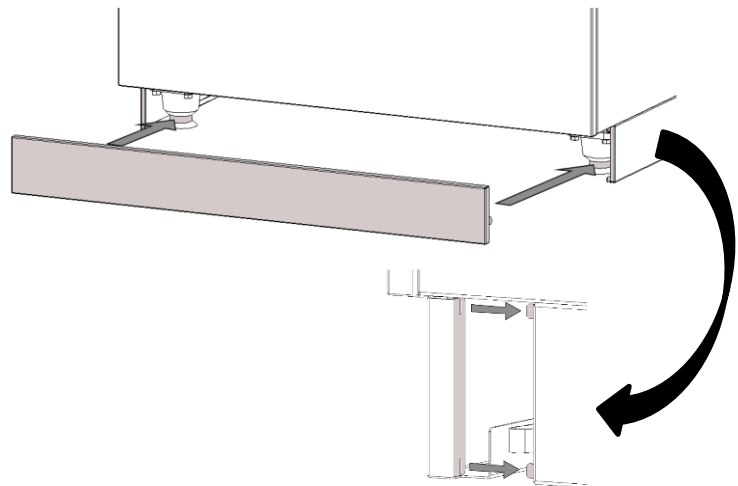

Result

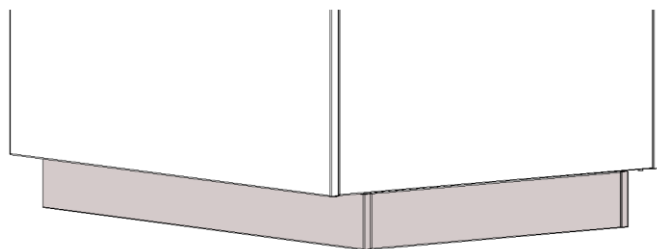

3.2.3 Mounting front doors (optional)

There are 2 different heights of plastic washers to align the height of the front doors.

Position the doors with the handles to the outside and with the warning sticker above the handle.

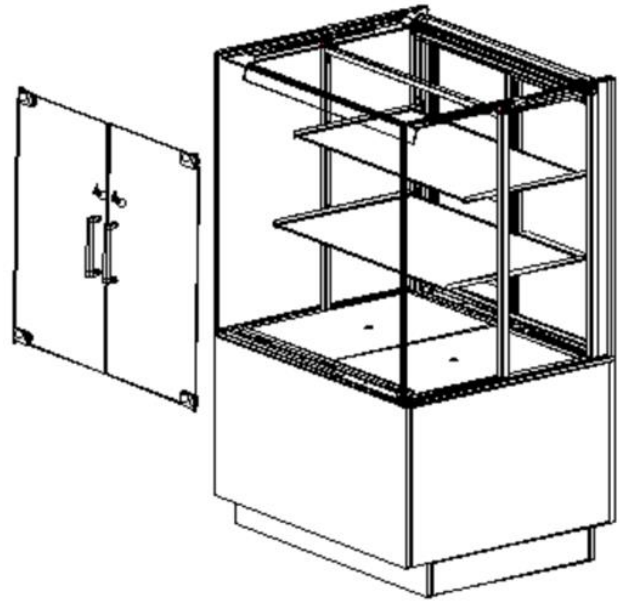

Put the thick or thin plastic washer (depending on leveling) on the bottom hinge pin of the door. Do this at all doors.

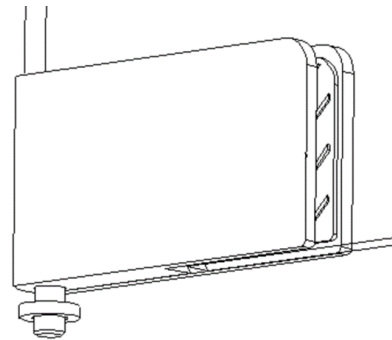

Place the hinge pin with the plastic washer on in the bottom hole (A). Keep the door in a tilted position during this action.

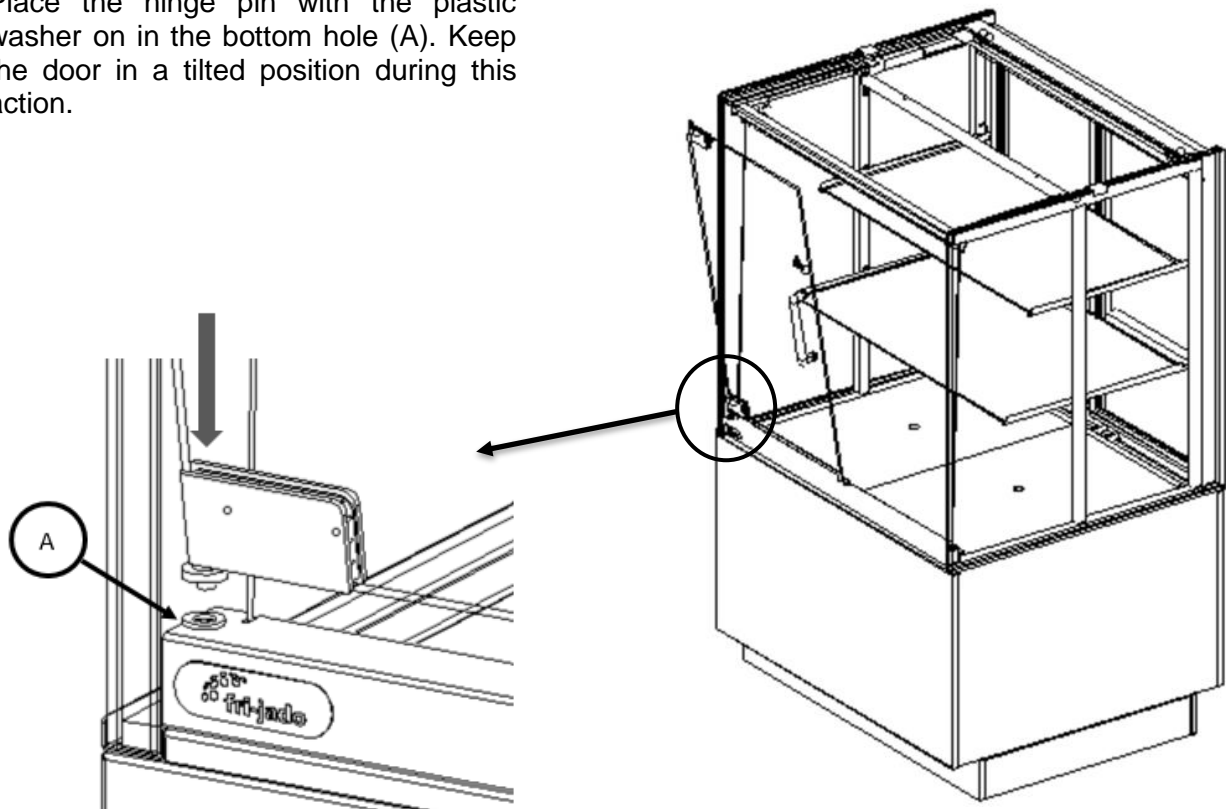

Press the hinge pin at the upper side downwards. Turn the door in a 'vertical' position so the upper hinge pin will align with the upper hole. Release the hinge pin into the upper hole (B).

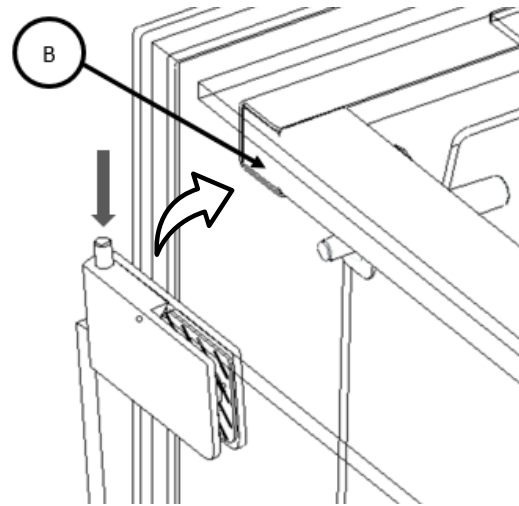

If both hinge pins are correctly clicked into the bottom and upper hole, the door is mounted correctly.

Result

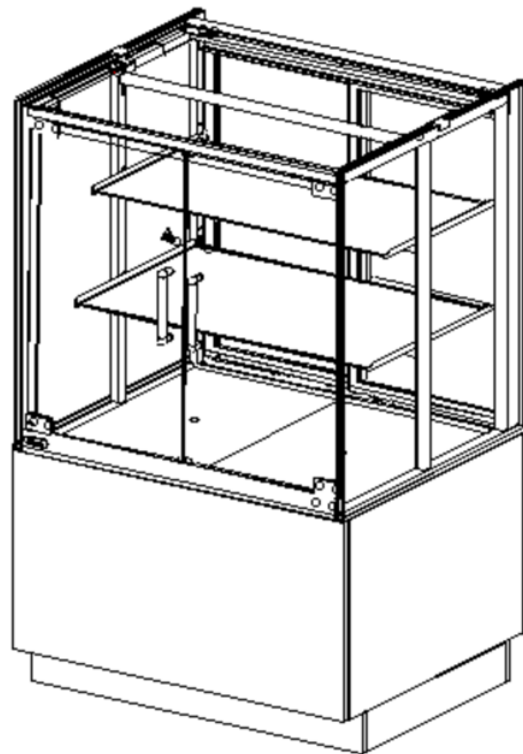

3.2.4 Applying price rail

Optional price rails for Hot self-serve models can be mounted using the front screws underneath each of the Hot SS shelves. Price rails for full serve models can be mounted on the air inlet grill and on the glass shelves. Cold self-serve models are supplied with price rails as standard. Refer to installation manual.

3.3 Drop-in units

For installation of the Drop-in units refer to instruction 9124589.

3.4 Repositioning the glass shelves

3.4.1 Cold FS/SS models & Hot FS models

The glass shelves can be positioned at three horizontal levels (I), or one of the three angled positions (II and III) by changing the positions of the LED-armature with respect to the rear.

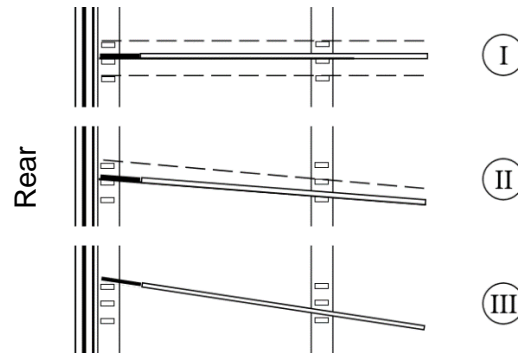

In order to change to any of these positions, follow the steps in the example below to change from a horizontal to an angled position. Reverse the steps to change to a horizontal position from an angled position.

1. Carefully lift the glass shelf out of its side supports.

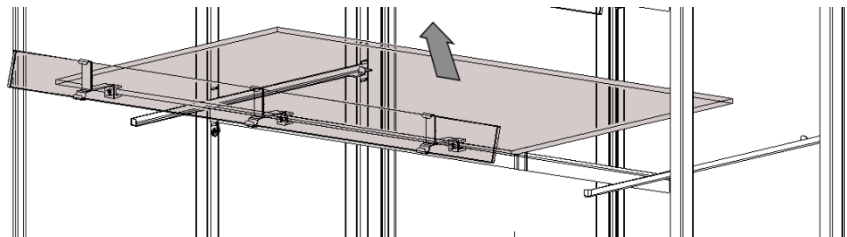

2. Remove the side supports from the rear columns by rotating them out.

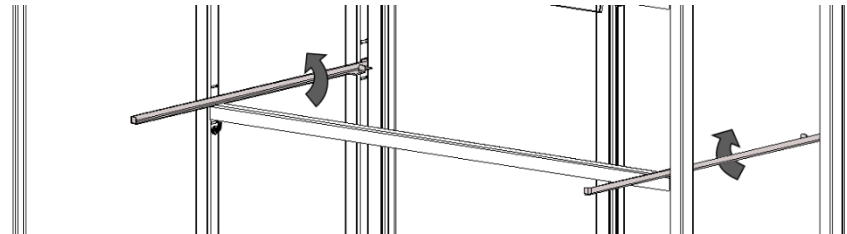

3. Lift the LED-armature from its supports, but be careful to not strain, clamp or otherwise damage the cable.

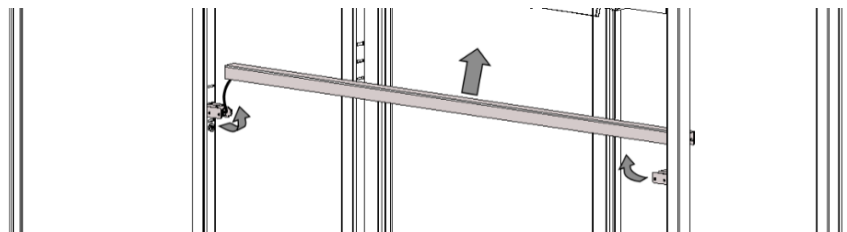

4. Reposition the LED-armature supports by taking them out of the central column and inserting them back in at the desired level.

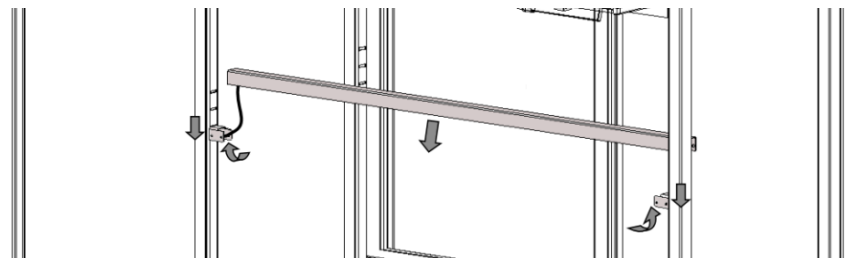

- Position the side supports at the desired height by inserting them into the rear column. Let the front end rest on the LED-armature.

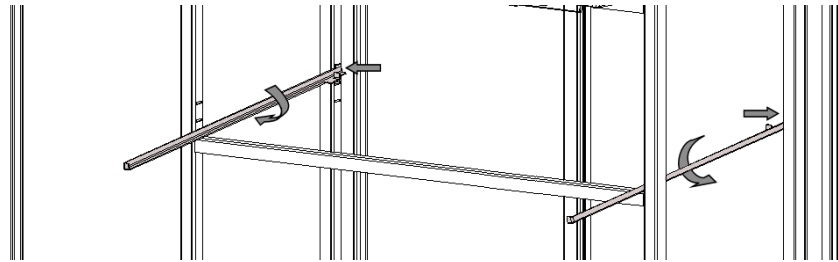

Please note that the rear level is supposed to be located at an equal or higher level than the LED-armature.

- Place the glass shelf back onto its supports.

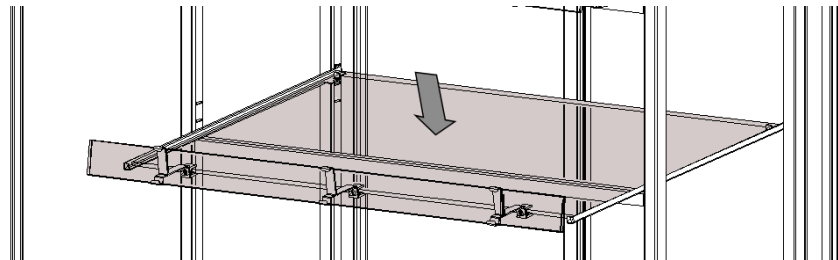

3.4.2 Hot SS models

The glass shelves can be positioned at two angled positions (0° and 3°). Refer to installation manual.

3.5 Plateau Options

On all MCC models, except the MCC Hot SS, the bottom presentation deck can be set at a variety of horizontal levels (I, II, III) and angles (IV, V, VI) as seen in the sideview cross-section for different display experiences.

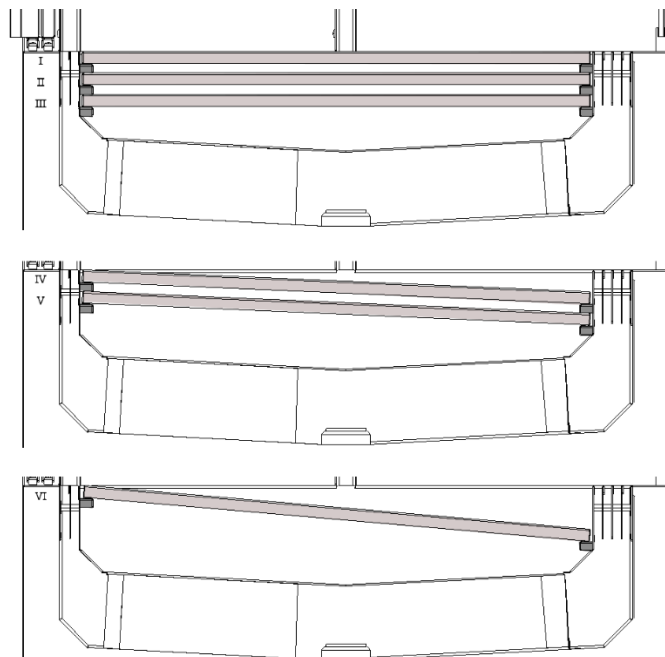

To change to a different position:

- Remove the plateaus from the unit.
- Reposition the supports at the front and the back to the desired positions.
- Place the plateaus back in the unit.

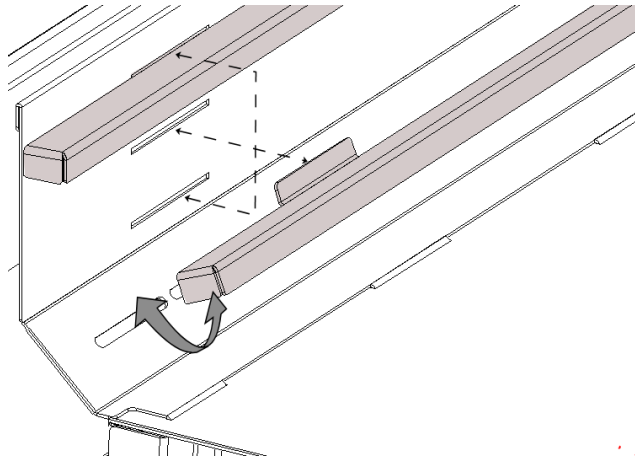

3.6 Hot FS models (Humidification)

3.6.1 Water connection automatic

When connect to the water supply the Hot FS will fill the water tray automatic when the water level is too low.

How to connect the water supply:

- Remove the front panel screws.
(When delivered with under frame.)
- Remove the front panel.

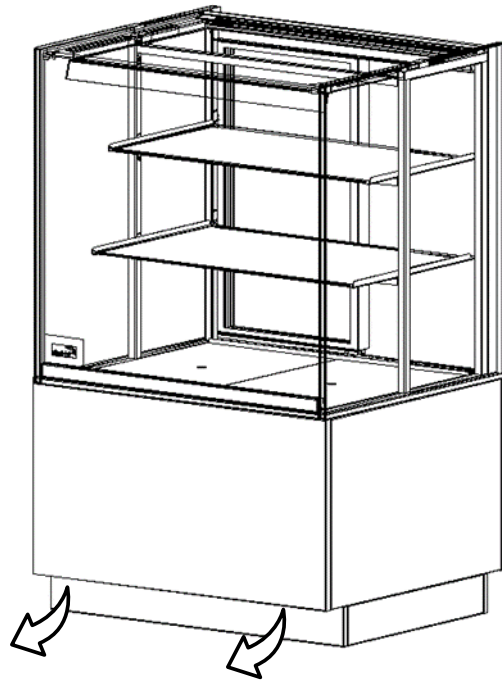

- Connect the water supply hose to the inlet pipe of the water tray.
- Remount the front panel and secure it with the screws.

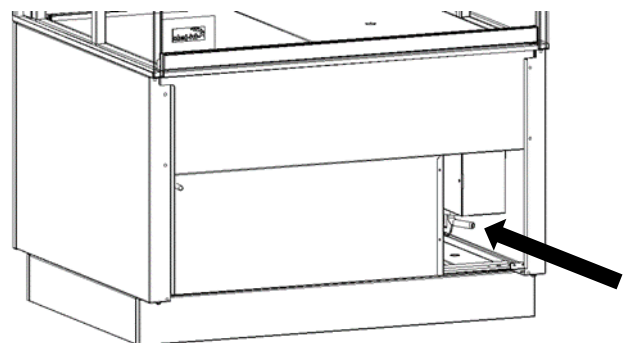

3.6.2 Manually fill

- When the water level in the reservoir drops below the minimum level, an alarm light will light up underneath the Humidifier button.

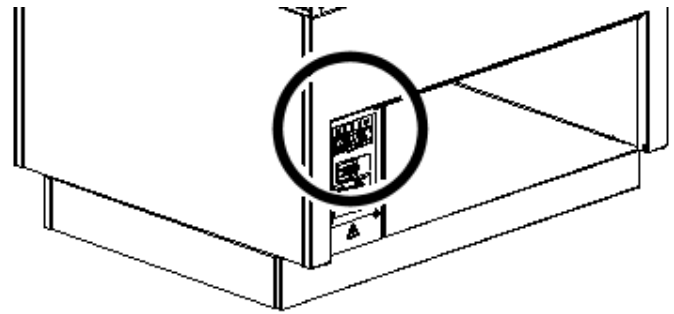

- Fill the water tray. Look for the required volume of water in the table below.



Warning

Do not overfill the water tray!

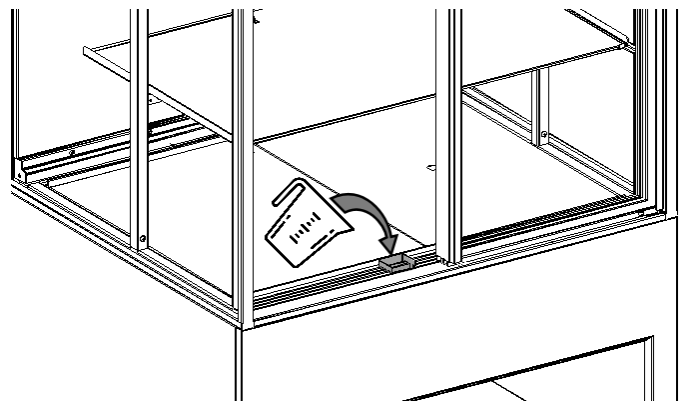

Unit	GN tray size	Max. reservoir water level	Reservoir water level when alarm activates	Max. water volume to add (only when alarm is on!)
MCC-60 H FS	GN 1/2 40mm	2,5L (0.66 gallon)	0,75L (0.19 gallon)	1,75L (0.46 gallon)
MCC-90 H FS	GN 1/1 40mm	5L (1.32 gallon)	1,5L (0.39 gallon)	3,5L (0.92 gallon)
MCC-120 H FS	GN 1/1 40mm	5L (1.32 gallon)	1,5L (0.39 gallon)	3,5L (0.92 gallon)

- Once the water reservoir has been filled. Switch the alarm button of the humidifier 5 second off and switch it back on.

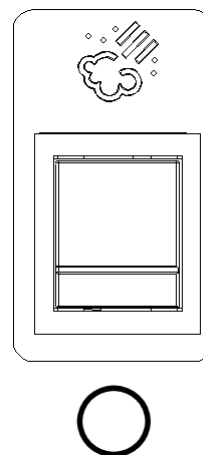

3.7 First use

Before starting to use the unit, clean the inside thoroughly with mild detergent and water. After cleaning it wipe it with a cloth moistened with clean water to remove residual detergent, then dry the entire unit.



Warning regarding to automated humidifier:

When filling the water tray for the first time, water may come out of the pipe at high speed. This is the result of air that was trapped in the pipe or water hose.

4. OPERATION AND USE



The display and/or set value is not the product/unit temperature.

4.1 Cold Units



Cold units are factory programmed to achieve a product temperature $\leq 5\text{ }^{\circ}\text{C}$ ($41\text{ }^{\circ}\text{F}$) at an ambient of $25\text{ }^{\circ}\text{C}$ ($77\text{ }^{\circ}\text{F}$) with a relative humidity of 60% by a max. draft of 0.2 m/s (0.66 ft/sec). This corresponds with a 3M1 classification according to ISO 23953:2015.

The set temperature can be changed from $-6\text{ }^{\circ}\text{C}$ to $+0\text{ }^{\circ}\text{C}$ ($21.2\text{ }^{\circ}\text{F}$ to $32\text{ }^{\circ}\text{F}$).

Temperature controller

- 1 Display
- 2 Up and Down keys
- 3 Escape/Stand-by key (power on)*
- 4 Enter key



* Switch on/off: hold for approx. 3 sec.

Switching-on the unit

- Switch the cooling on by means of the temperature controller.
- Let the unit cool for approx. 30 minutes.

Loading the unit

- Only load products of which the temperature is maximum $4\text{ }^{\circ}\text{C}$ ($39.2\text{ }^{\circ}\text{F}$).
- The maximum loading height is 50mm (2 inch) below the bottom of the shelf/air guide above.
- The maximum carrying-capacity per shelf is 30 kg/m (66 lbs/m), by equal load.

Checking the temperature

- During operation the display of the thermostat shows the temperature in the unit. The maximum reading must not exceed $5\text{ }^{\circ}\text{C}$ ($41\text{ }^{\circ}\text{F}$).
- The indication  will light when the cooling is active.

Locking/unlocking the keypad (when applicable)

- The keypad locks automatically in the following situations:
 - On start-up,
 - After 30 seconds of inactivity.

Checking the SET temperature

1. Press and release **SET** to access the “Machine status” menu.
2. Scroll through the folders with Δ and ∇ until you find the folder **Pb1**, **Pb2** or **Pb3**.
3. Press **SET** to view the value measured by the corresponding probe.

Notes:

- the displayed value cannot be changed.
- folder **Pb2** can only be viewed on models that manage probe Pb2.
- folder **Pb3** can only be viewed on models that manage probe Pb3.

Adjusting the SET Temperature

1. Press and release **SET** to access the “Machine status” menu.
2. Scroll through the folders with Δ and ∇ until you find the folder **SET**.
3. Press **SET** to view the current setpoint value.
4. Change the setpoint value using Δ and ∇ within 15 seconds.
5. To confirm the value press **SET** or ⏻ , or let a timeout occur (15 seconds).

Checking the product temperature

- Once every hour, the product temperature should be checked using a digital thermometer. Write down the measured values in a log.
- Always use a disinfected thermometer sensor.

Switching off

- Remove all products from the unit. In order to avoid temperature rise of the products, store them in another cooling unit.
- Switch the cooling off.

4.2 Hot Unit



The unit is set at 65 °C (149 °F) intake air temperature for the self-service model and 80 °C (176 °F) for the full serve model. If required this temperature can be adjusted to some degree.

At a ambient temperature of 20 °C (68 °F) and an initial core temperature of 85 °C (185 °F) these factory settings of the unit's temperature ensure a constant core temperature of at least 63 °C (145.5 °F) for 4 hours.

Control Panel

On/Off Switches.

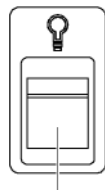

Lighting

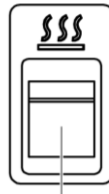

Heating

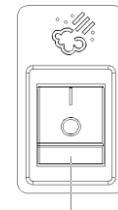

Humidifier
(Option)

Temperature controller

- A1 Indication ON
- A2 Display temperature
- A3 UP-button (power on/off)*
- A4 SET-button
- A5 DOWN-button

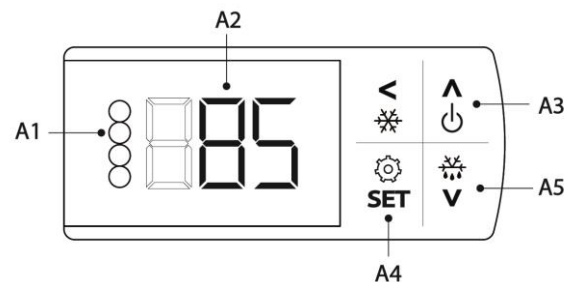

* Switch on/off: hold for approx. 3 sec.

Switching-on the unit

- Switch the heating on.
- Preheat the unit for approx. 30 minutes.
- Switch on the lighting.
- Humidification (FS model only): apply water supply / manual fill (see section 3.6).

Loading the unit

- Only place products that have a core temperature of at least 85 °C (185 °F).
- Only package the hot products in bags or containers that are suitable for this purpose.
- To ensure a good contact with the heated trays, only place a single layer of products.
- The maximum loading height is 50mm (2 inch) below the bottom of the shelf/air guide above.
- The maximum carrying-capacity per shelf is 30 kg/m (66 lbs/m), by equal load.

Checking the temperature in the unit

- During operation the display of the thermostat shows the temperature at the probe in the unit. The indication ON will light when the elements are active.

Checking the SET temperature

- During operation the display of the thermostat shows the temperature in the unit.
- Push once on the SET-button. The set temperature will appear on the display.
- The display will show the temperature in the unit after 20 seconds.

Adjusting the SET Temperature

- During operation the display of the thermostat shows the temperature in the unit.
- Push once on the SET-button. The set temperature will appear on the display.
- Adjust the set temperature by means of the UP-button and the Down-button .
- Push once on the SET-button to store the new set temperature.

Checking the product temperature

- Once every hour, the product temperature should be checked using a digital thermometer. Write down the measured values in a log.
- Always use a disinfected thermometer sensor.

Switching off

- Remove all products from the unit. In order to avoid temperature drop of the products, store them in another warm holding unit.
- Switch the heating off.
- Switch the lighting off.
- FS model only: close water supply when applicable.

5. CLEANING AND MAINTENANCE



WARNING

Never use a water hose for cleaning. Water can seep into the unit through the ventilation holes of the unit.

Appliances must be disconnected from their power supply during cleaning or maintenance and when replacing parts.



Because of hygiene aspects and optimum condition of the unit it is of utmost importance to keep a daily cleaning pattern from first use onwards.

5.1 Maintenance schedule

Item	Action	Frequency
Inside	<ul style="list-style-type: none"> Clean, see section 5.2. 	Daily
Humidifier	<ul style="list-style-type: none"> Remove any calcium build-up in the water tray and on the pins of the water level sensor. Possible detergent: hot water and vinegar. 	Weekly
Outside	<ul style="list-style-type: none"> Clean, see section 5.3. Use Stainless Steel cleaning spray to remove stains, and restoring the gloss. 	Weekly
Glass panes	<ul style="list-style-type: none"> Clean, see section 5.4 	Weekly
Bottom air guides	<ul style="list-style-type: none"> Clean, see section 5.5 	Weekly
Condenser	<ul style="list-style-type: none"> Clean, see section 5.6. 	Monthly

5.2 Daily Cleaning

- Clean the inside of the unit with hot water and a suitable cleaner.
- After cleaning wipe the inside with a clean wet cloth. Be sure that the detergent is removed properly.
- Do not use excess water in case a cold unit is fitted with an evaporation tray as it could overflow.

5.3 Weekly Cleaning



WARNING

The control panel may only be cleaned using a damp cloth.

- Clean the outside of the unit with a small amount of hot water and a mild cleanser and using a soft brush or sponge. After cleaning it dry the outside with a cloth.
- Treat all cleaned surfaces with a suitable antibacterial agent.
- Rub dry with a soft cloth or a paper towel.

5.4 Cleaning Glass Panes

Cleaning the top glass pane

For all MCC variants, lift and hold the top glass while cleaning the top glass pane.

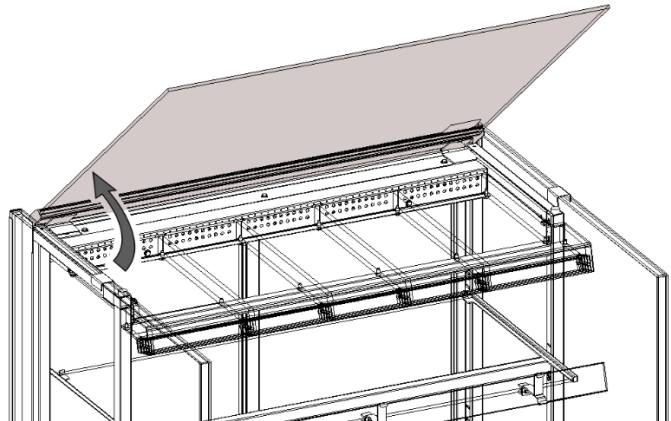

Cleaning the top air guides



WARNING

Do not use detergents and other cleaning products that may damage polycarbonate. Using inappropriate products to clean may tarnish, scratch or even crack any polycarbonate surfaces.

For all the MCC Models, the transparent air guide pane can be removed for cleaning.

- Lift and hold up the top glass pane throughout the process.
- The air guide pane is laid up freely and somewhat flexible and can as such easily be removed from its support on the rear by applying a light amount of torsion.
- After cleaning, place the air guide pane back by applying some light torsion.
- Close the top glass pane.

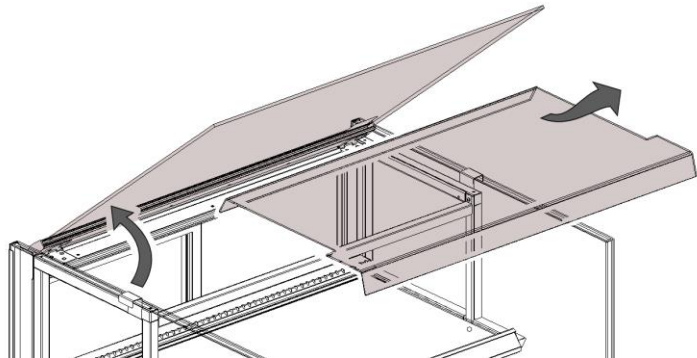

For the MCC Cold SS model only: It is imperative to maintain both hygiene and transparency on the in and outside of the top air box.

- Lift and hold up the top glass pane throughout the process.
- Remove the air box cover by sliding it out and clean it.
- Clean each of the air box's compartments.
- Slide the air box cover back in place.
- Close the top glass pane.

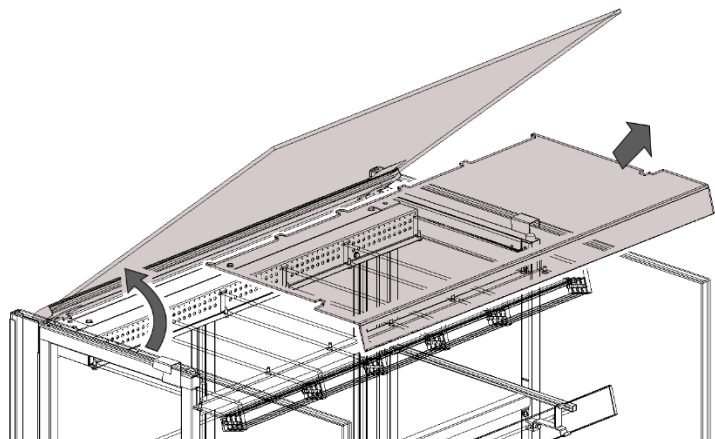

Cleaning the side double-glass pane

- Slide the double glass pane towards the front along the top (A) and bottom (B) guiding rails. The side pane can be removed from the unit once it has slid in its entirety past the top guide.

CAUTION: Once past the top guide, the glass pane might fall if not properly held. Hence do not leave it standing upright without being supported by both guide rails or holding it.

- It is recommended to only move the pane to such an extent that the pane areas next to the support columns can be cleaned.
- To clean the guiding rails, the pane can be removed in its entirety.
- If the pane was removed and needs to be placed back in, before sliding the pane back into the rails, ensure the transparent sides of the pane are facing forwards and up. Then slide it all the way back till the front of the pane is in line with the front plating.

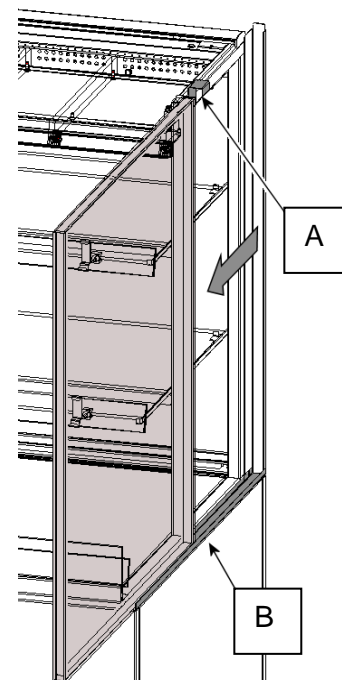
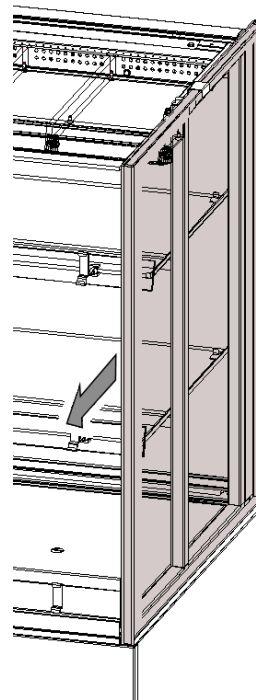

Cleaning front window

- Lift and hold the top glass, the front glass will automatically remain in position.

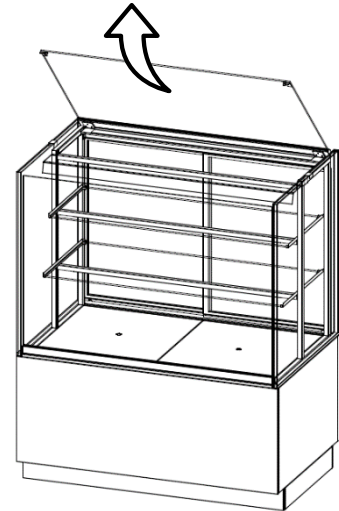

- Gently tilt the front glass forward (do not drop) whilst holding the top glass.

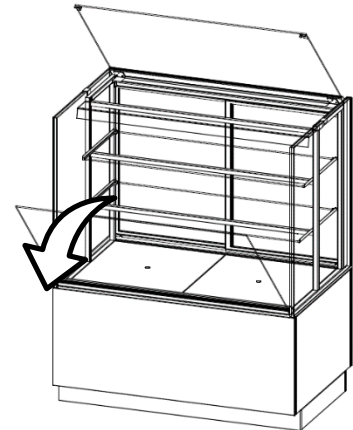

- Lower the top glass back in place.
- Clean the front glass.

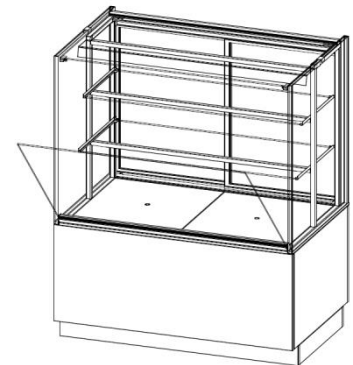

- **Closing:**
Lift and hold the top glass whilst closing the front glass. A positive snap will make sure it stays into the upright position.

- Gently lower the top glass back in place. Ensure the tabs on the edge of the top glass fit over the edge of the front glass.

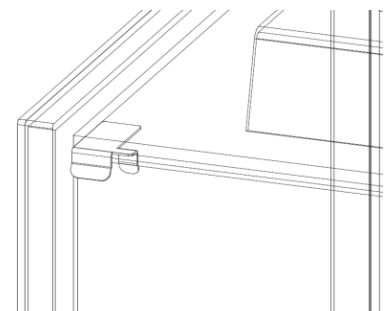

Cleaning sliding doors and rear of shelves



Always keep the sliding doors closed as much as possible, or the unit cannot maintain its climate. Cleaning the sliding doors is therefore recommended during off-hours. Follow the following steps to access the inner sides of the sliding doors and the rear of the hot or cold shelves for cleaning.

- Slide the right (outermost) door open until its slot aligns with the guiding pin.

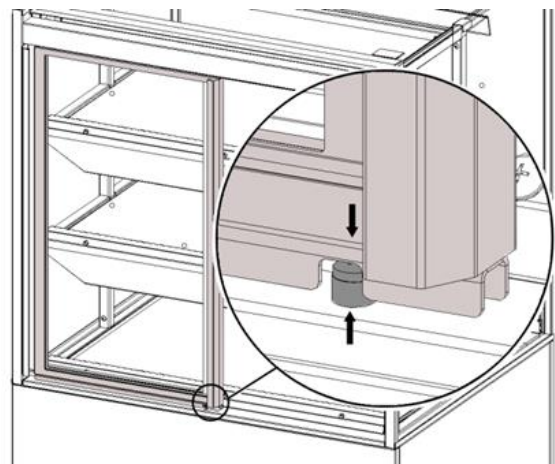
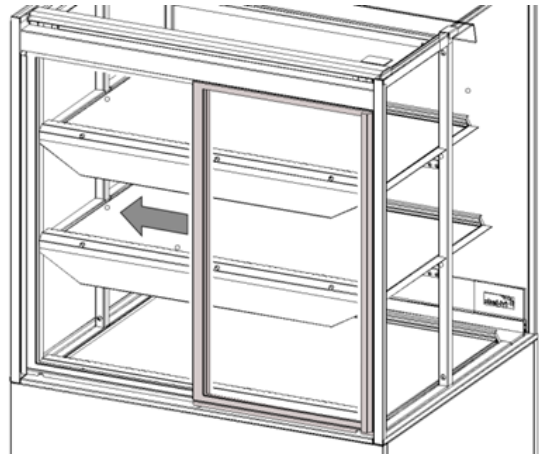

- Turn the outermost door outwards along the guiding pin. Clean the outermost door.

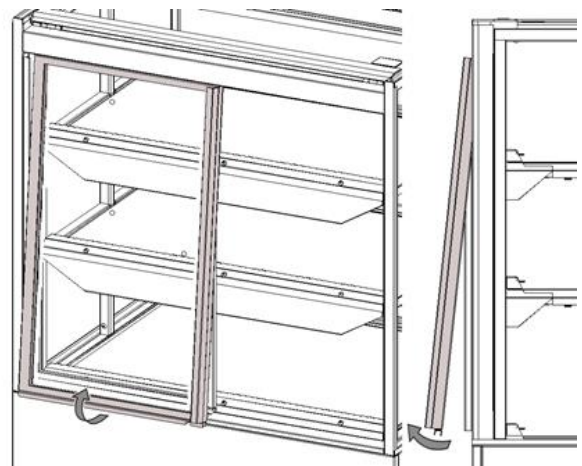

- To clean the left (innermost) door, slide both doors to the right until the innermost door's slot aligns with the guiding pin.

NOTE: The outermost door should still be in its rotated position.

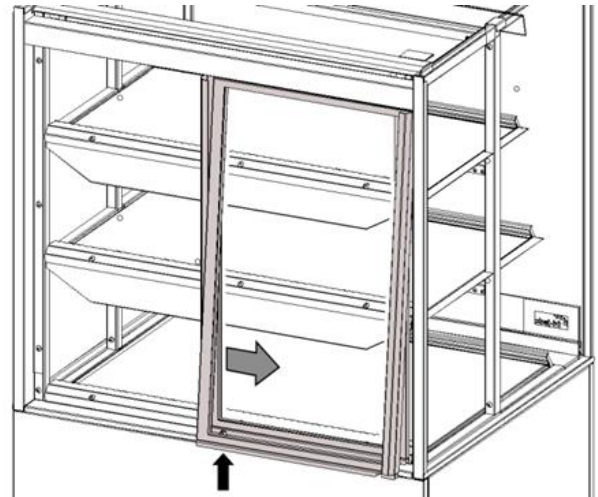

- Turn the innermost door outwards as well to clean it.

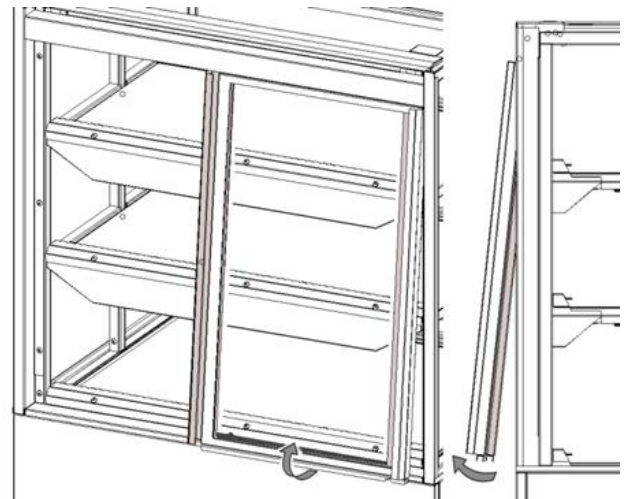

- Follow the above steps in reverse order to return both doors to their original positions. And close both doors.

Cleaning front door(s) (optional)

- Clean the outside of the front doors.

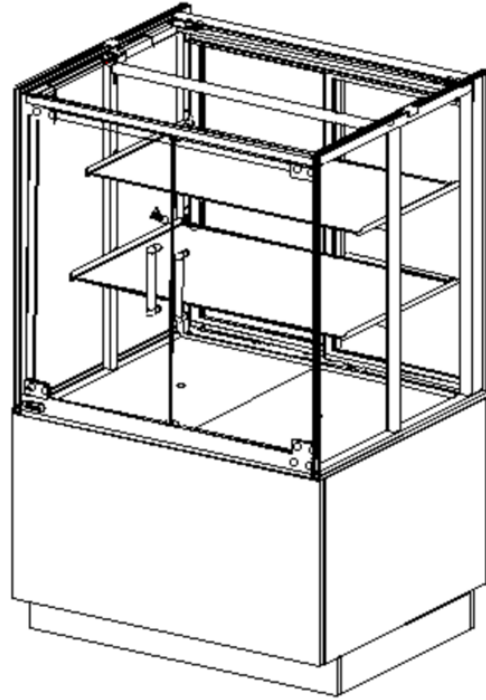

- Open the front doors and clean the inside of the doors in the same way as the outside.

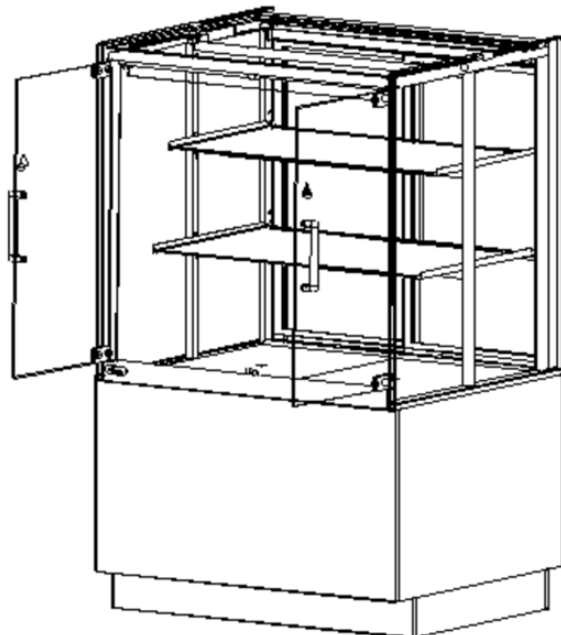

5.5 Cleaning air guides and fans Hot FS models



WARNING

Switch off the unit first and let it cool down.
Be aware of rotating parts.

- Remove first the plating of the lower presentation deck.

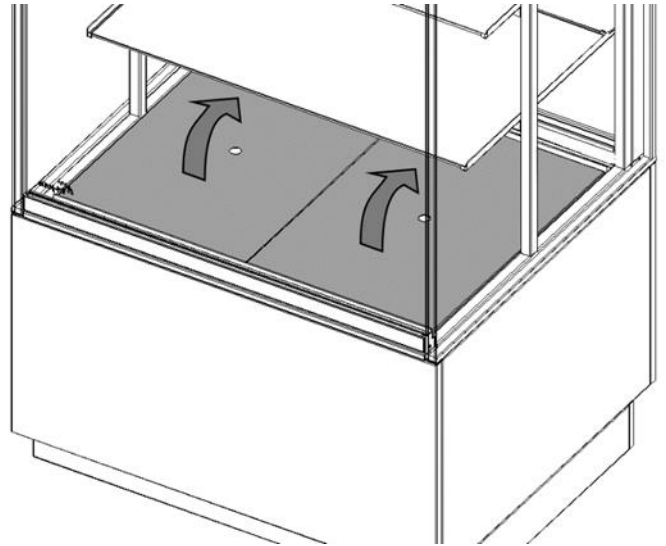

- Remove the plating above the water tray.

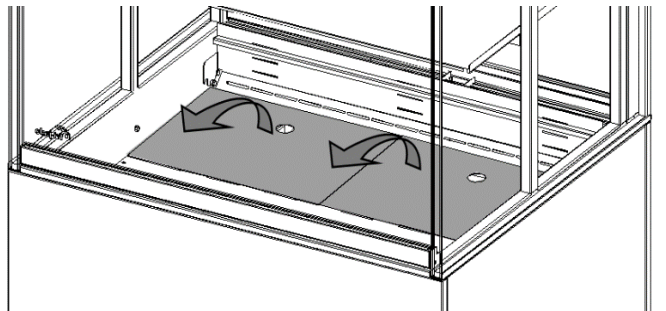

- To clean the inlet (A) and outlet (B) air guides.

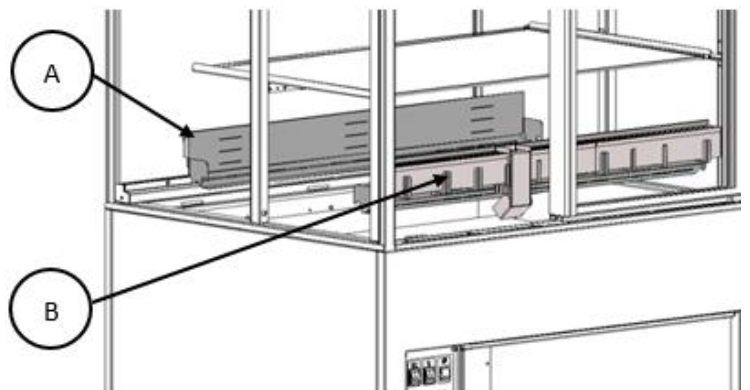

- Remove the inlet air guides at the frontside and clean them.

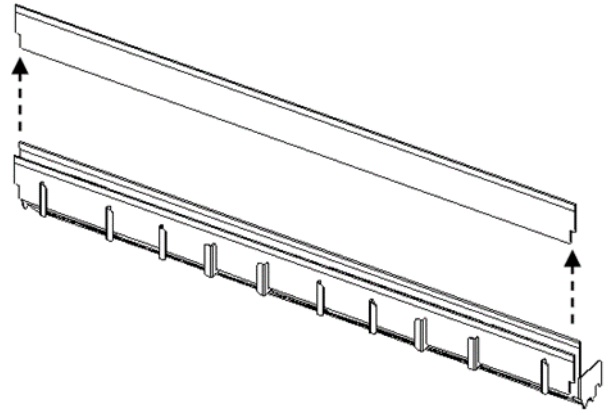

- Remove the outlet air guides at the backside and clean them.

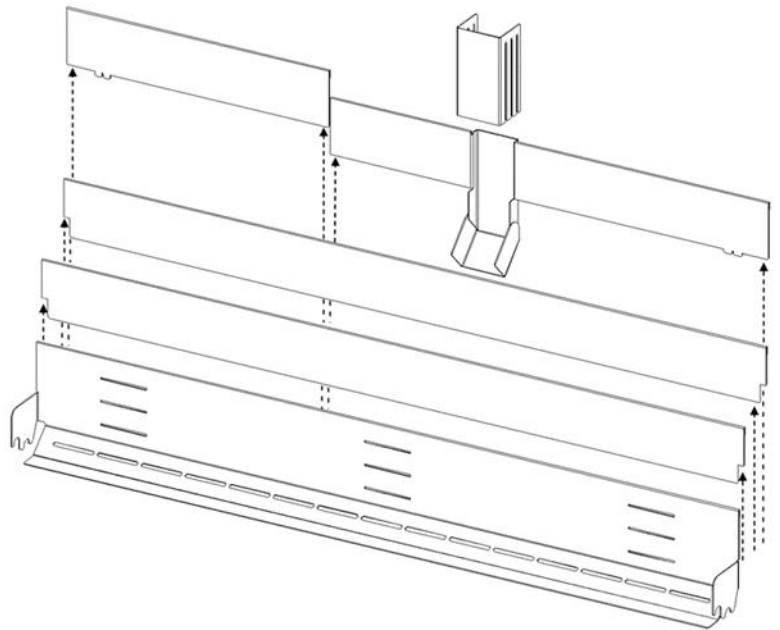

- Clean the fans (when needed) with a brush. Fans are positioned below the inlet air guides.

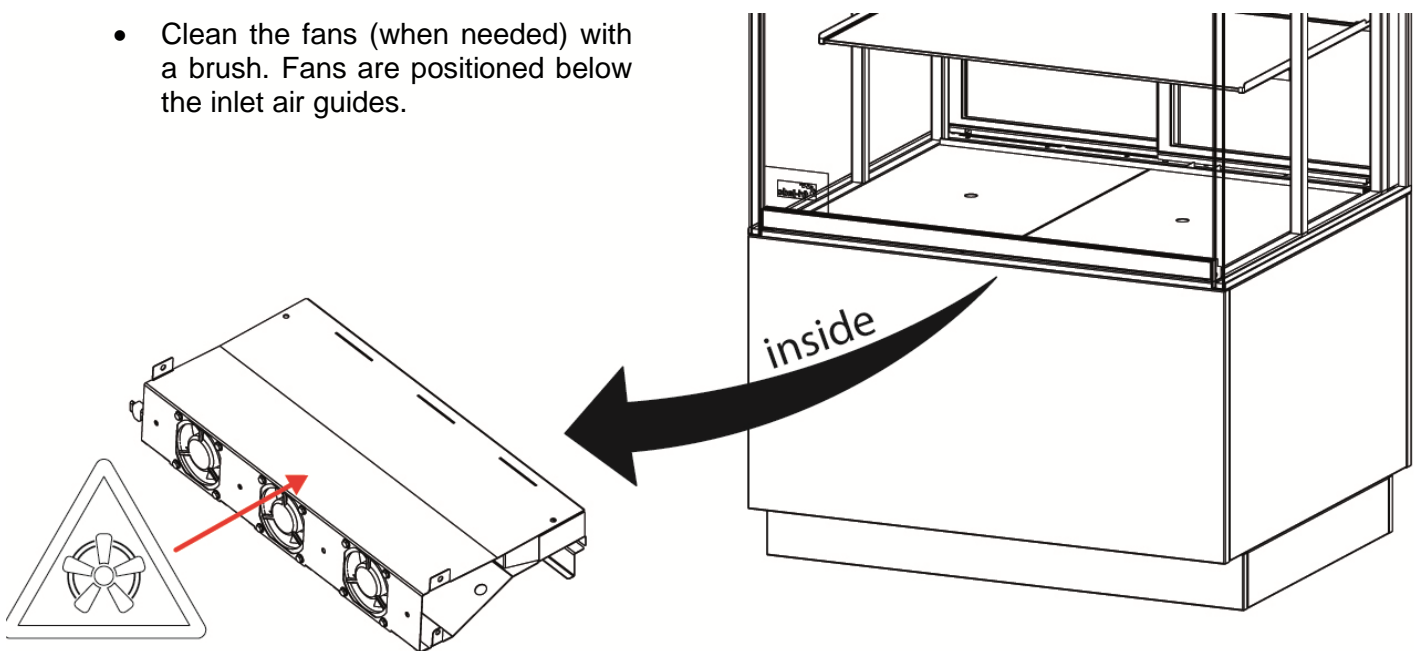

- Follow the above steps in reversed order to reassemble the air guides and plates.

5.6 Cleaning the condenser (Cold units)



WARNING

Cleaning of the condenser must be performed by qualified persons and in a well ventilated environment.

Unscrew the condenser cover and open it.

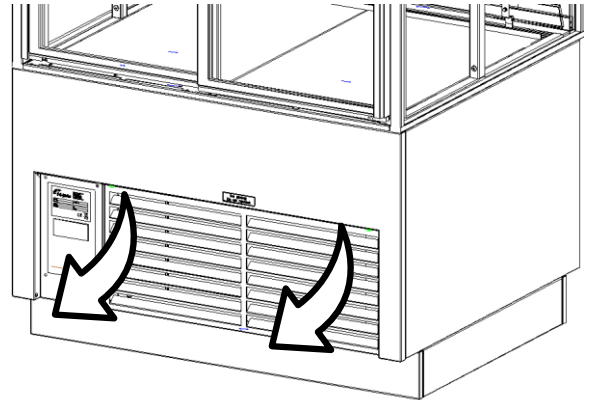

WARNING

Do not damage the aluminum condenser plates.

Clean the condenser using a long haired soft brush and a vacuum cleaner.

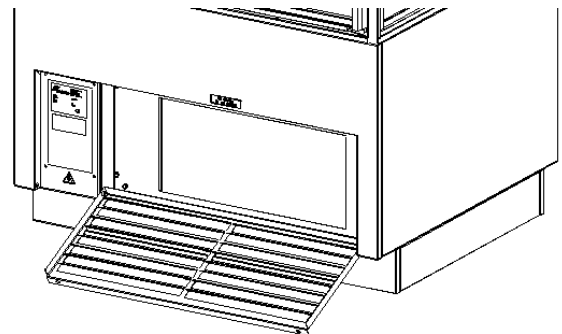

Close the cover and screw the bolts back.

6. MALFUNCTIONS AND SERVICE

Before you consult your dealer or the service agency when there is a fault, you can check the following points yourself:

- Is the power supply OK? Check the fuses and the earth leakage switch in the meter cupboard.
- Are all the switches in the correct position?

Item	Malfunction	Possible action
Unit	Unit does not work	<ul style="list-style-type: none"> • Check the power supply. • Are all switches in the correct position.
Unit	Display shows error code	<ul style="list-style-type: none"> • Contact your supplier or service agency.
Lamp	Does not light up	<ul style="list-style-type: none"> • Switch ON.
Humidifier	Warning light humidifier	<ul style="list-style-type: none"> • Check water level/supply. • Reset by pushing the switch for a few seconds.
Mains cord	Damaged	<ul style="list-style-type: none"> • Replace, see section 6.2.
Window	Damaged	<ul style="list-style-type: none"> • Replace, contact your supplier or service agency.

6.1 Cold units



WARNING

All service operations on the refrigeration system and gas charging must be performed by qualified persons and in a well ventilated environment.

6.2 Replace the mains cord



WARNING

Hazardous electrical voltage.

If the mains cord is damaged, it must be replaced by the manufacturer, his service agent or a similarly qualified person in order to avoid hazards.

7. TECHNICAL SPECIFICATIONS



WARNING

Consult the identification plate to get the proper specifications of the unit. The electrical data may vary from country to country.

7.1 Cold units

Cold Self-service models

Model	MCC 90-3-C SS	MCC 120-3-C SS	MCC 150-3-C SS
Approved for	EU	EU	EU
Width	900 mm	1200 mm	1500 mm
Depth	750 mm	750 mm	750 mm
Height on stand	1420 mm	1420 mm	1420 mm
Height above worktop	840 mm	840 mm	840 mm
Weight Net Approx.	173 kg / 382 lbs	199 kg / 439 lbs	225 kg / 496 lbs
Ambient Temperature	min. 17 °C / 62.6 °F max. 25 °C / 77 °F	min. 17 °C / 62.6 °F max. 25 °C / 77 °F	min. 17 °C / 62.6 °F max. 25 °C / 77 °F
Relative humidity	max. 60%	max. 60%	max. 60%
Noise level (at workplace)	<70 dB(A)	<70 dB(A)	<70 dB(A)
Voltage	1N~ 230V	1N~ 230V	1N~ 230V
Frequency	50 Hz	50 Hz	50 Hz
Max. nominal Current ¹	4 A	4.6 A	5.6 A
Plug	2 pole earthed plug 16A	2 pole earthed plug 16A	2 pole earthed plug 16A
Length power cord approx.	1.5 m	1.5 m	1.5 m
Climate Class (EN-ISO 23953-2:2015)	3 (25 °C/60%RH)	3 (25 °C/60%RH)	3 (25 °C/60%RH)
Minimum room floor area	8.13 m ²	10.53 m ²	12.92 m ²
Refrigerant ²	R290	R290	R290
Refrigerant charge	170 g	220 g	270 g

¹ Excluding optional evaporation tray

² R290 = Propane gas

Cold Full-service models

Model	MCC 90-3-C FS	MCC 120-3-C FS	MCC 150-3-C FS
Approved for	EU	EU	EU
Width	900 mm	1200 mm	1500 mm
Depth	750 mm	750 mm	750 mm
Height on stand	1420 mm	1420 mm	1420 mm
Height above worktop	840 mm	840 mm	840 mm
Weight Net Approx.	175 kg / 386 lbs	202 kg / 445 lbs	229 kg / 505 lbs
Ambient Temperature	min. 17 °C / 62.6 °F max. 25 °C / 77 °F	min. 17 °C / 62.6 °F max. 25 °C / 77 °F	min. 17 °C / 62.6 °F max. 25 °C / 77 °F
Relative humidity	max. 60%	max. 60%	max. 60%
Noise level (at workplace)	<70 dB(A)	<70 dB(A)	<70 dB(A)
Voltage	1N~ 230V	1N~ 230V	1N~ 230V
Frequency	50 Hz	50 Hz	50 Hz
Max. nominal Current ³	3.9 A	4.2 A	5.2 A
Plug	2 pole earthed plug 16A	2 pole earthed plug 16A	2 pole earthed plug 16A
Length power cord approx.	1.5 m	1.5 m	1.5 m
Climate Class (EN-ISO 23953-2:2015)	3 (25 °C/60%RH)	3 (25 °C/60%RH)	3 (25 °C/60%RH)
Minimum room floor area	8.13 m2	10.53 m2	12.92 m2
Refrigerant ⁴	R290	R290	R290
Refrigerant charge	170 g	220 g	270 g

³ Excluding optional evaporation tray

⁴ R290 = Propane gas

7.2 Hot units

Hot Self-service models

Model	MCC 60-3-H SS	MCC 90-3-H SS	MCC 120-3-H SS
Approved for	EU	EU	EU
Width	600 mm	900 mm	1200 mm
Depth	750 mm	750 mm	750 mm
Height	1420 mm	1420 mm	1420 mm
Weight Net Approx.	152 kg / 335 lbs	179 kg / 395 lbs	206 kg / 454 lbs
Ambient Temperature	min. 20 °C / 68 °F max. 30 °C / 86 °F	min. 20 °C / 68 °F max. 30 °C / 86 °F	min. 20 °C / 68 °F max. 30 °C / 86 °F
Relative humidity	max. 60%	max. 60%	max. 60%
Noise level (at workplace)	<70 dB(A)	<70 dB(A)	<70 dB(A)
Voltage	1N~ 230 V	1N~ 230 V	3N~ 400/230 V
Frequency	50 Hz	50 Hz	50 Hz
Max. nominal Current	8.2 A	12.7 A	7.1 A
Plug	2 pole earthed plug 16A	2 pole earthed plug 16A	CEE-form 16 A
Length power cord approx.	1.5 m	1.5 m	1.5 m

Hot Full-service models

Model	MCC 60-3-H FS/SS Hum.	MCC 90-3-H FS/SS Hum.	MCC 120-3-H FS/SS Hum.
Approved for	EU	EU	EU
Width	600 mm	900 mm	1200 mm
Depth	750 mm	750 mm	750 mm
Height	1420 mm	1420 mm	1420 mm
Weight Net Approx.	152 kg /335 lbs	179 kg / 395 lbs	206 kg / 454 lbs
Ambient Temperature	min. 20 °C / 68 °F max. 30 °C / 86 °F	min. 20 °C / 68 °F max. 30 °C / 86 °F	min. 20 °C / 68 °F max. 30 °C / 86 °F
Relative humidity	max. 60%	max. 60%	max. 60%
Noise level (at workplace)	<70 dB(A)	<70 dB(A)	<70 dB(A)
Voltage	1N~ 230V	1N~ 230V	1N~ 230V
Frequency	50/60 Hz	50/60 Hz	50/60 Hz
Max. nominal Current	7.5 A	8.1 A	11.2 A
Plug	2 pole earthed plug 16A	2 pole earthed plug 16A	2 pole earthed plug 16A
Length power cord approx.	1.5 m	1.5 m	1.5 m
Water supply pressure	≥ 150 kPa	≥ 150 kPa	≥ 150 kPa

Notes.

Notes.

Notes.

Fri-Jado B.V.
Blauwhekken 2
4751 XD Oud Gastel
The Netherlands
Tel: +31 (0) 76 50 85 400

Fri-Jado Inc.
1401 Davey Road, Suite 100
Woodridge IL 60517
USA
Tel: +1-630-633-7950

www.frijado.com